

PBSS8110T TRANSISTOR (NPN)

FEATURES

- Complementary Type FM5T593

MAXIMUM RATINGS (T_a=25°C unless otherwise noted)

Symbol	Parameter	Value	Unit
V _{CBO}	Collector-Base Voltage	120	V
V _{CEO}	Collector-Emitter Voltage	100	V
V _{EBO}	Emitter-Base Voltage	5	V
I _C	Collector Current	1000	mA
P _C	Collector Power Dissipation	250	mW
R _{θJA}	Thermal Resistance From Junction To Ambient	500	°C/W
T _j	Junction Temperature	150	°C
T _{stg}	Storage Temperature	-55~+150	°C

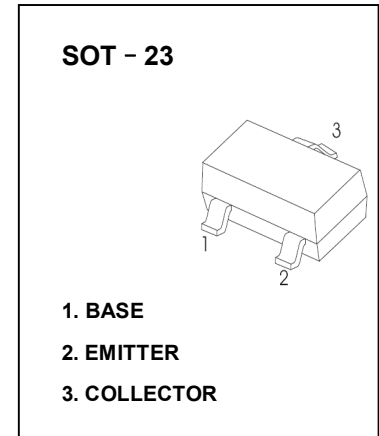

ELECTRICAL CHARACTERISTICS (T_a=25°C unless otherwise specified)

Parameter	Symbol	Test conditions	Min	Typ	Max	Unit
Collector-base breakdown voltage	V _{(BR)CBO}	I _C =100μA, I _E =0	120			V
Collector-emitter breakdown voltage	V _{(BR)CEO}	I _C =10mA, I _B =0	100			V
Emitter-base breakdown voltage	V _{(BR)EBO}	I _E =100μA, I _C =0	5			V
Collector cut-off current	I _{CBO}	V _{CB} =100V, I _E =0			0.1	μA
Collector cut-off current	I _{CES}	V _{CE} =100V, I _E =0			0.1	μA
Emitter cut-off current	I _{EBO}	V _{EB} =4V, I _C =0			0.1	μA
DC current gain	h _{FE(1)} *	V _{CE} =10V, I _C =1mA	100			
	h _{FE(2)} *	V _{CE} =10V, I _C =250mA	100		300	
	h _{FE(3)} *	V _{CE} =10V, I _C =0.5A	60			
	h _{FE(4)} *	V _{CE} =10V, I _C =1A	20			
Collector-emitter saturation voltage	V _{CE(sat)1} *	I _C =500mA, I _B =50mA			0.3	V
	V _{CE(sat)2} *	I _C =1A, I _B =100mA			0.6	V
Base-emitter saturation voltage	V _{BE(sat)} *	I _C =1A, I _B =100mA			1.15	V
Base-emitter voltage	V _{BE} *	V _{CE} =10V, I _C =1A			1	V
Transition frequency	f _T	V _{CE} =10V, I _C =50mA, f=100MHz	150			MHz
Collector output capacitance	C _{ob}	V _{CB} =10V, I _E =0, f=1MHz			10	pF

*Pulse test: pulse width ≤300μs, duty cycle ≤ 2.0%.

Typical Characteristics

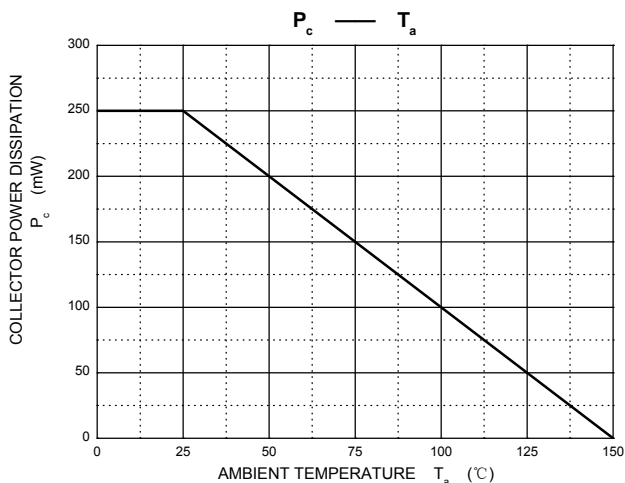
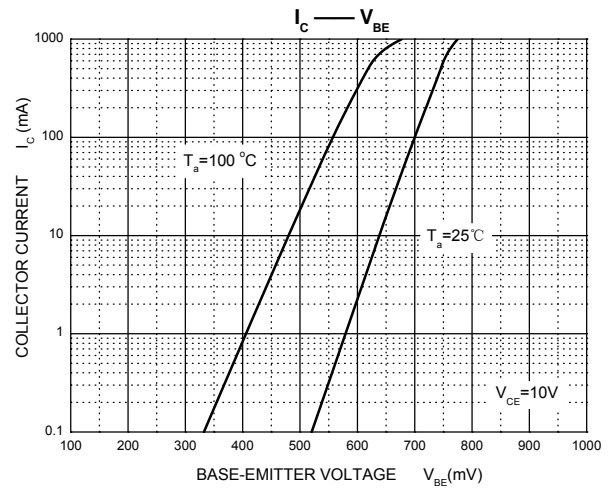
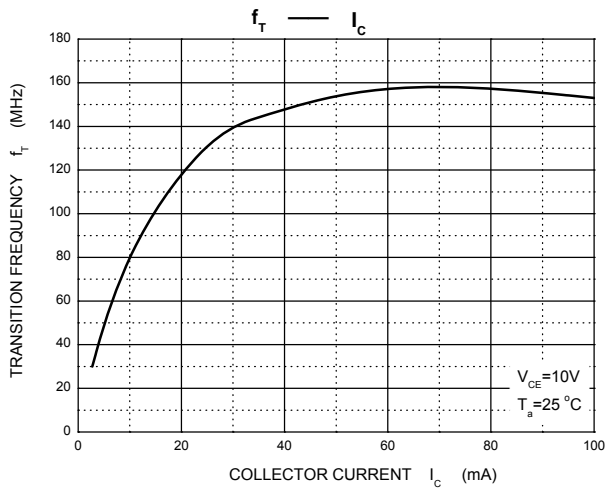
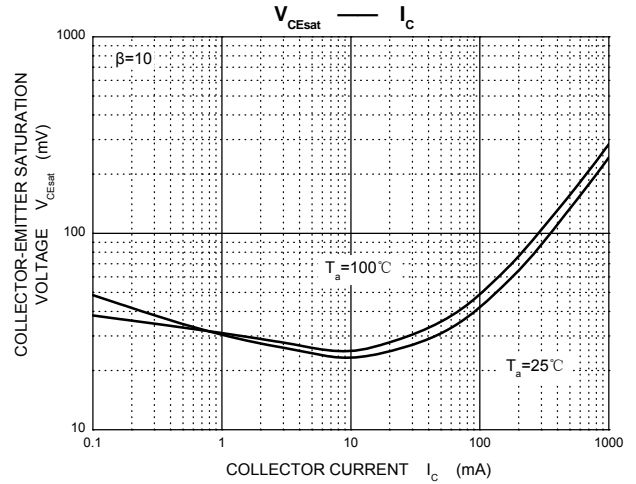
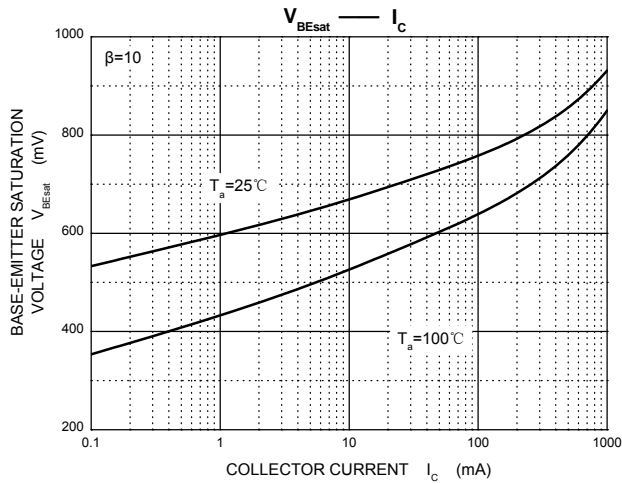
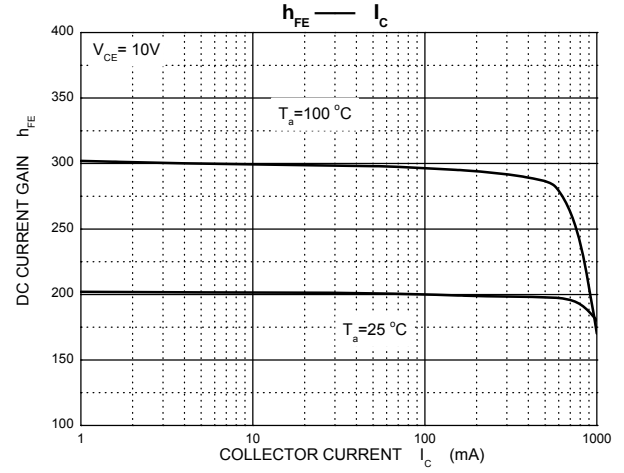
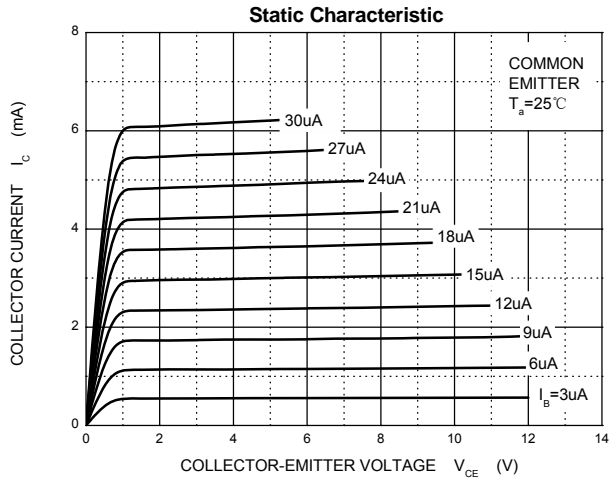

SOT-23 Package Outline Dimensions

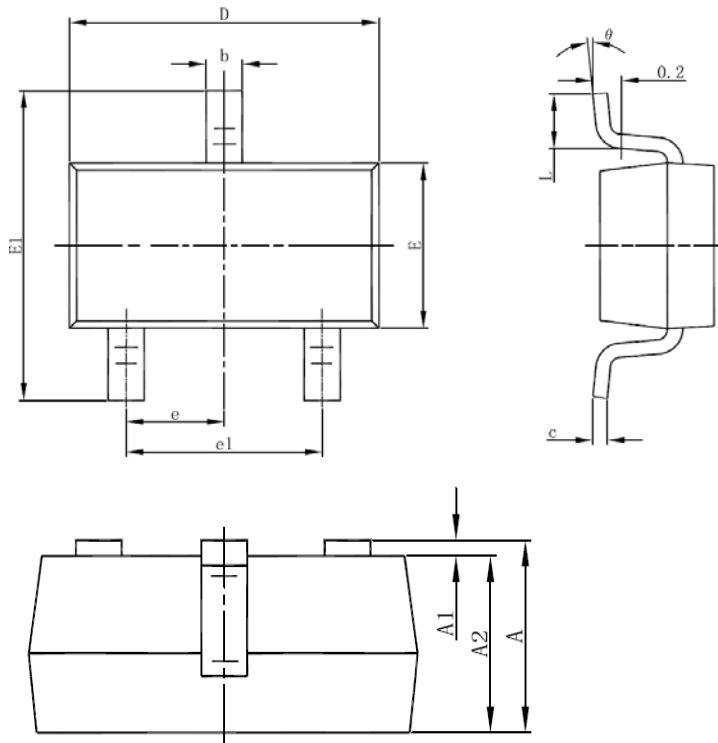

Symbol	Dimensions In Millimeters		Dimensions In Inches	
	Min	Max	Min	Max
A	1.050	1.250	0.041	0.049
A1	0.000	0.100	0.000	0.004
A2	1.050	1.150	0.041	0.045
b	0.300	0.500	0.012	0.020
c	0.100	0.200	0.004	0.008
D	2.820	3.020	0.111	0.119
E	1.500	1.700	0.059	0.067
E1	2.650	2.950	0.104	0.116
e	0.950(BSC)		0.037(BSC)	
e1	1.800	2.000	0.071	0.079
L	0.300	0.600	0.012	0.024
θ	0°	8°	0°	8°